

HIGH SPEED CENTRIFUGE



Instruction Manual



Model : LHSC-60

Please read this manual carefully before using the instrument

Labnics Equipment

• Table of Content •

CHAPTER	CONTENT	PAGE NO.
1.	Introduction	1
1.1	Specifications	1
1.2	Caution	1
1.3	Safety Instruction	2
2.	Note for Installation	4
2.1	Location	4
2.2	Balance	5
2.3	Electrical Requirements	5
3.	Parts Description	6
3.1	Control Panel	6
4.	Operation Procedure	7
4.1	Control Functions	7
5.	Maintenance	12
6.	Service Report	13

CHAPTER 1. INTRODUCTION :

1.1 Specifications:-

MODEL	LHSC-60
MAX RPM	21,000 rpm
MAX RCF	51,917 x g
MAX CAPACITY	6 x 500ml
SPEED DISPLAY	1rpm
TEMPERATURE RANGE	-20°C ~ 40°C
TIME	9HOUR 59MINUTE 59SECOND, CONTINUOUS OPERATING
BRAKE STAGE	10 STAGE
PROGRAM	10 memory
ROTOR	FIXED ANGLE ROTOR
DIGITAL DISPLAY	RPM, RCF, TIME, TEMPERATURE, PROGRAM, BRAKE SYSTEM
POWER SUPPLY	SINGLE PHASE 50 Hz, 230v, 1.8kw
DIMENSION (W x D x H) mm	550 x 600 x 865
WEIGHT (Kg)	110
DRIVE MOTOR	Brushless AC Induction Motor

1.2 Caution:-

OVERSPEED

All centrifuges have critical limitation of speeds, at vibration occurs. As the speed increases, beyond the critical speed, vibration will cease. The inherent conditions, also occurs during deceleration. Do not continuously operate this centrifuge at observed critical speeds.

IMBALANCE OF TUBE

A balanced load is essential for all centrifuges. An unbalanced load produces vibration, and can damage the unit. Always ensures that the rotor is loaded symmetrically, with a full complement of accessories, and a full set of tubes, tube adapters should also be installed symmetrically. Opposites places of the rotors must always be loaded with same accessories and filling. Eg. only one position I not allowed.

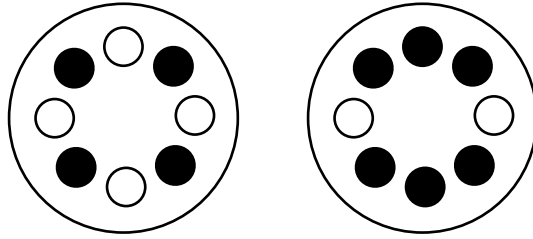

When you insert the tube, you must insert symmetrically.

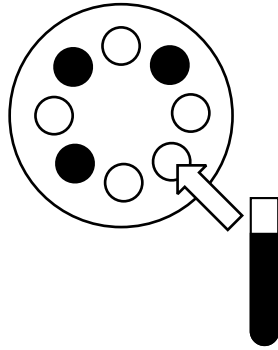

If the tubes is not symmetrical in number, You should insert same weight to use a new.

1.3 Safety Devices :

POWER ON/OFF



THE SYSTEM HAS AN AUTOMATIC CIRCUIT BREAKER, FOR EMERGENCY SITUATIONS, SUCH AS POWER SURGES, THAT COULD DAMAGE THE UNIT. USE AUTOMATIC CIRCUIT BREAKER TO PROTECT CIRCUIT CONTROLLER WHEN IT OVERPOWERED.

DOOR



THE ROTOR WILL STOP AUTOMATICALLY WHEN DOOR OPENS WHICH IS SENSING BY LIMIT SWITCH.

CHAMBER SAFETY



OTHER OF CHAMBER IS WELL DESIGNED AND INSTALLED WITH AMOR STEEL TO BE TO SUSTAIN UNEXPECTED HAZARDS.

SPEED



ALL CENTRIFUGES HAVE CRITICAL LIMITATION OF SPEEDS, AT WHICH VIBRATION OCCURS. AS THE SPEED INCREASES, BEYOND THE CRITICAL SPEED, VIBRATION WILL CEASE. THE INHERENT CONDITIONS, ALSO OCCURS DURING DECELERATION. DO NOT CONTINUOUSLY OPERATE THIS CENTRIFUGE AT OBSERVED CRITICAL SPEEDS.

VIBRATION



MOTOR WILL BE VIBRATED WHEN VIBRATING HEAVILY DURING SPINNING OF ROTOR. THIS SYSTEM SENSES VIBRATION OF MOTOR AND GIVES ALARM SOUNDS WITH FLASHING IMBALANCE LED. IT BEGINS TO START DECELERATE BASED ON POSING DECELERATION TIME. THIS SAFETY DEVICE CAN PROTECT ANY ACCIDENT IN THE LACK OF OPERATOR.

TEMPERATURE



IT GIVES ALARM SOUNDS WHEN THE UNIT IS OVER TEMPERATURE FROM THE SETTING LIMITATION OF TEMPERATURE

SYSTEM



THE UNIT FLASHES LIGHT WHEN PROBLEM OCCURS IN THE UNIT.

CHAPTER 2. NOTE FOR INSTALLATION:-

2.1 Location:-

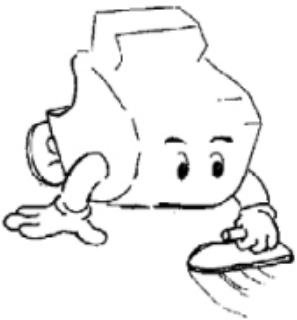

BEST LOCATION

THE RESETTING SURFACE MUST BE LEVEL. TO ENSURE QUITE VIBRATION-FREE OPERATION. A LOCK AND STABLE LOCATION IS IMPORTANT. IMPROPERLY LOADED CENTRIFUGE MAY VIBRATE OR MOVE



AIR CIRCULATION

ALL ENERGY CONSUMED BY THE CENTRIFUGE IS CONVERTED INTO HEAT AND EMITTED INTO THE AMBIENT AIR. THEREFORE, SUFFICIENT VENTILATION IS VERY IMPORTANT. AS THE AIR-DUCTS IN THE UNIT MUST BE OPEN, KEEP A CLEARANCE OF AT LEAST 30 CM AROUND CENTRIFUGE. ALSO, CENTRIFUGE SHOULDN'T BE POSITIONED NEAR RADIATORS AND SHOULD NOT BE DIRECTLY EXPOSED TO SUNSHINE.



TEMPERATURE & HUMIDITY

FOR NORMAL OPERATION THE AMBIENT TEMPERATURE SHOULD NOT BE FALL BELOW 10°C AND NOT EXCEED 35°C. THE MAX HUMIDITY OF AIR 80% DURING TRANSPORT FROM COLD TO WARMER PLACES WATER WILL CONDENSATE INSIDE THE CENTRIFUGE. IT IS IMPORTANT THAT THERE IS ENOUGH TIME FOR DRYING BEFORE THE CENTRIFUGE CAN BE STARTED AGAIN.



AVOID CORROSIVE GAS

SET UP IN THE PLACE WHERE CORROSIVE GAS DON'T OCCUR. IF SULFUR DIOXIDE AND CHLORINE GAS IN THE ATMOSPHERE, THE DAMAGE OF ALL PART OF STEEL CAN OCCUR AND CORROSION IN ROTOR AND AXIS CAN OCCUR

2.2 Balance:-



BALANCING

THE SHAFT SHOULD BE VERTICAL FROM THE GROUND. PUT YOUR BALANCE ON THE TOP OF MOUNTED ROTOR. YOU HAVE TO MAKE SURE THAT YOU HAVE YOUR BALANCE TO MAKE HORIZONTAL LEVEL ON THE TOP OF SPINNING SHAFT OR MOUNTED ROTOR ONLY. DO NOT MEASURE YOUR BALANCE. IT IS NOT MAKE HORIZONTAL WHEN YOU PUT YOUR BALANCE ON THE SURFACE OF MAIN CASE.

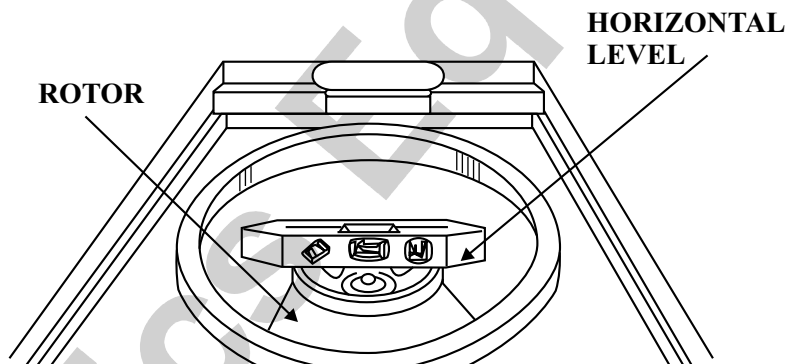

IN CASE OF DIFFICULT TO PUT BALANCE ON THE TOP OF SPINNING SHAFT, INSERT ROTOR INTO SHAFT AND PUT YOUR BALANCE WITHOUT COVER OF ROTOR AS SAME AS ABOVE PICTURE.

2.3 ELECTRICAL REQUIREMENTS:-



POWER

You must connect after certificating the table in the back panel of centrifuge, as it can change in accordance with order of user, though the power uses 220V. It's a single phase and you must care that it is not three phases that is used in the factory frequently. If the voltage changes from more than 10% to less than 10% in standard voltage, you can't get a precise reliance rates. In addition, the constant power must continue to be supplied as it can damage in various parts of centrifuge.

GROUNDING

Grounding method of centrifuge : Grounding line of our centrifuge is a green line of power line, and the power is a single phase power of 220V. If user want to certificate whether external grounding is connected well or not in the power line, user has only to certificate whether between one of black or white line and green line is 110V or not. In installation of product, if the conduct of grounding isn't acted well, as it can cause a wrong function of centrifuge, and electronic system of centrifuge can be damaged by external electronic shock, you have to do the conduct of grounding necessary.

Don't connect a grounding line in a water pipe, gas pipe, electronic line, lighting rod, telephone line. Especially, in case of a water pipe, although an exposed part is a coppered pipe, as grounding capacity is impossible to be connected PVC line in the middle of pipe sometimes, you had better avoid. And, in case of using a gas pipe as a grounding line, a fire by a flame can cause. In place of being wet, to institute an electronic leakage cut off is more and more safe.

CHAPTER 3. PARTS DESCRIPTION:-

3.1 Control Panel:-

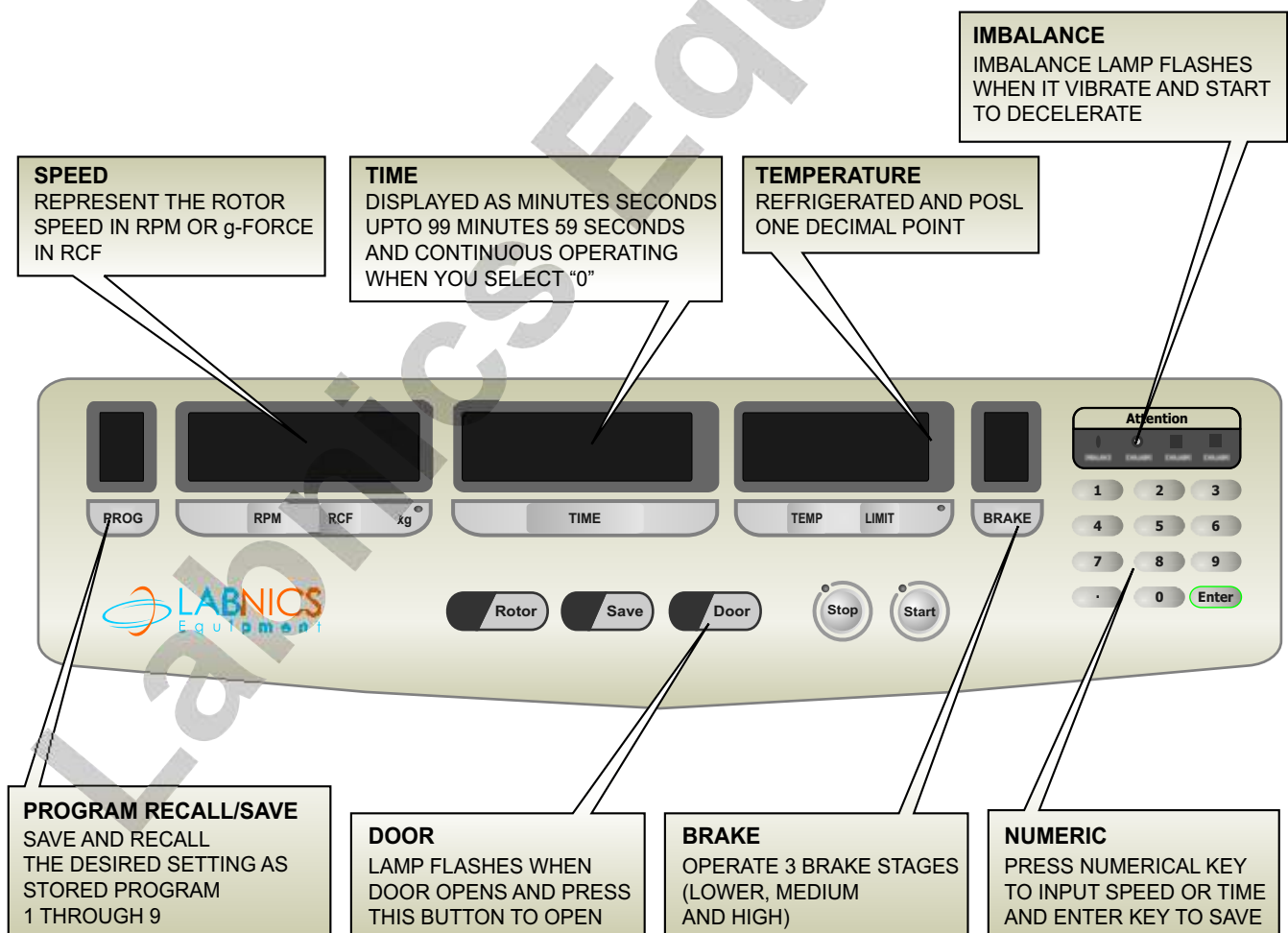

CHAPTER 4. OPERATION PROCEDURE:-

1. Power Supply

- Turn on the main power switch on the back of unit.
- Turn key switch to "On" position and lamps will be on and ready to use.
- There will be sounds and all displays will be on when you turn to "**Power on**".
- Position, the unit displays last saved on the control board.

2. Open the door and install the rotor onto the shaft

- Door will be opened when power on.
- Door will be closed automatically when the rotor starts to spin, door will be opened when rotor stops.
- Door will be open when press the door button on the controller during the spinning stage.



(Don't press door button when rotor spins)

3. Pose desired setting parameters

- Resetting desired data for RPM, Time, Temp. Brake system.
- Press control button to change for speed, time, temperature and so on.
- Flashes previous setting data.
- Input desired parameters.
- Press save button to save it.

4. Press "start" button to run the unit.

- Press start button to run the unit without changing any parameters such as rpm, time, temperature.
- The refrigeration system will run to calibrate, temperature and rotor will not run when actual temperature is not in the temperature limit range.
- The unit start to decelerate when it reach the time limit.
- Door will be opened when It stops and displays setting parameters.
- Press the stop button to stop operation.

4.1 Control Function :

RPM

Provide very precise rpm (every 4 rpm) and control system in this model 4 rpm, user can select desired rpm (every 1 rpm). Refrigeration system will only operate and rotor does not spin during posing operation time when posting "o" in rpm window. It's very efficient way to adjust chamber temperature as same as sample evenly.

Speed display unit	:	1 rpm
Speed setting unit	:	1 rpm
Speed accuracy	:	Maximum 0.5%

Setup

- Press RPM button on the controller.
- Previous setting data displays on displayed board and gives sound.
- RPM data will be returned to the main beginning point and flashing data will stop after pressing enter button.
- Use numeric button to pose desired setting parameters and press enter button to save.

RCF (x g)

- Displays current RCF in speed window when pressing RCF button on the control and xg lamp will be on simultaneously.
- RPM/RCF are calculated together.
- The unit calculate it's RCF automatically when user pose RPM, and also the unit displays its RPM when posting RCF, and the unit displays its RPM when posting RCF data.
- It can be changed its data when the unit operates.

RCF display unit

RCF setting unit

Setup

- Press PCF button on the control panel.
- Previous setting data displays and flashes lamp on displayed board and gives sound.
- RCF data will return to the main beginning point and flashing data will stop after pressing enter button.
- Use numeric button to pose desired setting parameters and press enter-button to save posing data will be flashing during posing desired data.

Time

Display range of operation time is from 0 to 9 hours 59 minutes, 59 seconds, displays 5 digits on the displayed board and it displays down counting of operation time from setting point and displays every seconds.

Setup

- Pressing TIME button on the control panel.
- Previous setting data displays and flashes lamp on displayed board and gives sound.
- Time data will return to the main beginning point and flashing data will stop after pressing enter button or temperature button.
- Use numeric button to pose desired setting parameters with shift lefting method and press enter - button to save posing data will be flashing during posing desired data.
- Free run when press "0" in the temperature window and decelerate and down counting until the end of operation time.
- Use FREE RUN function to operate more than 10 hours of centrifugation. Pose only "0" in the time window to use free run function for this unit.

Acceleration & Deceleration

- Acceleration time / Deceleration time control stages : 10 stages "0" is the slowest stages, "9" is the fastest stages. The unit will accelerate very quickly when posting "9" and will decelerate very quickly in case of "9" stage. It gives very high effective results of separation.

SETUP

- Press Brake button on the control panel .
- Previous setting data displays and flashes lamp on displayed board and gives sound.
- Time data will return to the main beginning point and flashing data will stop after pressing enter- button.
- Use numeric button to pose desired setting parameters and press-enter button to save posing data will be flashing during posing desired data.

Temperature

Display temperature in 3 digits and input one decimal point. Precise temperature measurement and control (0.1°C).

Temp. setting range	:	-20°C ~ + 40°C
Temp. display unit	:	0.1°C
Temp. setting unit	:	0.1°C
Temp. accuracy	:	0.5°C (horizontal temp)

SETUP

- Press Temperature button on the control panel.
- Previous setting data displays and flashes lamp on displayed board and gives sound.
- Temperature data will return to the main beginning point .

NOTE :

- Stop after pressing enter button or temperature button.
- Rotor is not working one minute to protect compressor after pressing start button to stabilize power supplying with power on.
- Please just wait and will start to operate normally, compressor will stop when posing "100" in the TEMP window.
- It's very convenient to stop operation compressor.
- Refrigeration system will only operate without spinning rotor in the chamber after when posing "0" in rpm window and pressing start button. It's very efficient way to adjust chamber temperature as same as sample evenly. User can keep their sample with rotor in the centrifuges under this condition.

Procedure

Posing 4 in the temperature and posing 5 in the Temp setting range. Compressor will operate without spinning rotor when posing "0" in the RPM. Begin to operate when temperature displays and maintain 4 degree in the chamber.

Time

Display range of operating time is from 0 to 9 hours 59 minutes, 59 seconds, display 5 digits on the displayed board and it displays down counting of operation time from setting point and displays every second.

SETUP

- Pressing TIME button on the control panel.
- Previous setting data displays and flashes lamp on displayed board and gives sound.
- Time data will return to the main beginning point and flashing data will stop after pressing enter button or temperature button.
- Use numeric button to pose desired setting parameters with shift lefting method and press enter-button to save posing data will be flashing during posing desired data.
- Free run when press "0" in the temperature window and decelerate and down counting until the end of operating time.
- Use FREE RUN function to operate more than 10 hours of centrifugation. Pose only "0" in the time window to use free run function for this unit.

ACCELERATION & DECELERATION

Acceleration time / Deceleration time control stages : 10 stages "0" is the slowest stages, "9" is the fastest stages. The unit will accelerate very quickly when posing "9" and will decelerate very quickly in case of "9" stage. It gives very high effective results of separation.

SETUP

- Press Brake button on the control panel.
- Previous setting data displays and flashes lamp on displayed board and gives sound.
- Time data will be returned to the main beginning point and flashing data will stop after pressing enter button to save posing data will be flashing during posing desired data.

Program (Save)

Capabilities of saving 10 programs from 0 to 9.

How to save Can be change with new desired operating parameters.

SETUP

How to save

- Press the program button to recall saved program.
- It displays previous saved number and gives sounds.
- Press the enter button and stop flashing.
- Pose desired number in the program window and press the enter button after posing new operation parameters to save desired parameters, it will change and displays new data on the displayed board.

Program (Recall)

Capabilities of recalling 10 programs from 0 to 9.

SETUP

How to recall

- Press the program button to recall saved programs.
- It displays previous saved number and gives sounds.
- Press the enter button and stop flashing.
- Pose desired number in the program window and press the enter button after posing new operating parameters to save desired parameters.
- it will change and displays new data on the displayed board.

Imbalance

The unit give alarm sounds with flashing lamp and starts to decelerate according in time limit at the time of heavy vibration of the unit and rotor imbalance situation.

Door

Press the foot pedal on the right hand side to open and pull up the door. The unit will not be operated while door opened. Press start button to operate with closed door.

Power supply will be stop when door open. Please do not try to open door during centrifugation. The button is located in the right hand side of the unit.

Operation

Press “Start” button to operate the unit with posing desired parameters.

Stop

The unit will decelerate when reaching setting operating time limit. And the unit will stop operating when pressing “stop” button on the control panel.

CHAPTER 5. MAINTENANCE:-

This chapter explains how to keep your unit in good operating order. It includes instructions for cleaning, decontaminating and storing. This chapter also covers the cover interlock by pass.

Care and cleaning:

Keep your centrifuge clean, to ensure good operation, and to extend its life.

Clean the sample chamber, rotor and lid at the end of each work day and immediately after any spill. To clean the chamber, use a damp sponge, warm water, and a mild liquid detergent, suitable for washing dishes by hand. Don't use caustic detergents or detergents that contain chlorine ions. These attack metals.

Remove stubborn stains with a plastic scrub pad. Don't use steel wool, wire brushes, abrasives, or sandpaper. They create corrosion sites. Never pour water directly into the rotor chamber. Scrub the rotor's tube cavities with a stiff test tube brush that has end bristles and a non-metallic tip. Dry each part, after cleaning, with a clean, absorbent towel.

If glass breakage occurs, remove all broken glass embed in the plastic or rubber accessories. Glass particles can come in contact with new glass tubes, creating pressure points that may result in breakage recurring. Glass particles, in the chamber, grind to a fine gray dust, during centrifugation. This dust can coat the inside of the centrifuge.

Storage:

Store parts on a soft surface, to avoid damage. Rotors and other parts should be clean and dry. Store them open to the air, not in a plastic bag, so that any residual moisture evaporates. Face the parts upward to avoid moisture retention in the cavities.

Decontamination :

If tube breakage occurs, releasing toxic, infectious, pathogenic, or radioactive material into the unit, decontaminate the chamber.

Rotors have sealed containers that provide aerosol containment and, if used as directed, keep spillage confined. If breakage occurs, it may be sufficient to only decontaminate the sealed carriers.

Cover door lock :

The cover will remain locked, if power fails. If you need to remove samples from the unit, before power is restored, use the cover door-lock, after the rotor has come to a stop.



Labnics Equipment

43040 Christy St., Fremont, CA 94538 USA.

Toll Free : (877) 620 9992

Tel. : (925) 271 4322

Fax : (925) 886 0400

Email : info@labnics.com Website : www.labnics.com