

CO₂ INCUBATOR



Instruction Manual



Model : LCI - 100B

Please read this manual carefully before using the instrument

Labnics Equipment

COPYRIGHT

1. Without the written permission of our company, any content of the manual should by no means be duplicated or disclosed to any other individual or organization.
2. Individual or organization should in no way use the manual unless authorized by our company.
3. Our company has the sole right to change or modify this manual. Any other individual or organization thereby should in no case change or modify the manual.
4. Without our written permission, any organization or individual should not, by the name of sale or donation, provide public the manual or the duplication of the manual.
5. Anyone who violates our copyright must be pursued according to the copyright law.

LABNICS EQUIPMENT

- No part of this publication may be reproduced or transmitted in any form by any means, including photocopying and recording, without the written permission of **LABNICS EQUIPMENT**.
- Various sections of this operating manual may be copied only for in-house use by the equipment operator, e.g. to provide employees with instruction on accident prevention measures. These sections are clearly marked in the list of contents.
- **LABNICS EQUIPMENT** can accept no liability or responsibility for the marketability or the suitability of his operating manual for a certain purpose other than that specified under "Areas of application of equipment".
- **LABNICS EQUIPMENT** reserves the right to change the version of this operating manual at any time and without prior notice.

Environmental Conditions:-

- Indoor use.
- Altitude up to 2,000 m.
- The working temperature of the surrounding must be in 18°C--30°C when the unit works in 37°C.
- Maximum relative humidity is 80% for temperatures up to 30°C.
- **MAINS** supply voltage fluctuations up to ± 10 & of the nominal voltage.
- Transient over voltages typically present on the **MAINS** supply category II.
- Applicable RATED POLLUTION degree 2.
- The room must be equipped with adequate ventilation.
- The setup surface must be firm, level, and nonflammable.
- The unit must be set up where it will not be in direct sunlight.
- There is not any hot source nearby the unit.

Safety Information:

- It is important for you to read this Instruction Manual carefully before using the unit for the first time.
- The CO₂ Incubator may only be operated by trained, authorized personnel.
- Maintenance work on the unit may only be performed by the **LABNICS EQUIPMENT** or authorized agents.
- Tissue, materials, or liquids:
 - Which are highly flammable or potentially explosive.
 - Whose vapors form flammable or explosive mixtures with air.
 - Which release toxins; May not be used.
- The pressure of the CO₂ supply can be adjusted to a range of 0.8-1 bar, and cannot be altered.
- CO₂ is a kind of gas representing potential health hazard. The unit is to be repeated at suitable intervals.
- Only qualified personnel using suitable tools may work on supply lines and compressed gas container, bottles, or collective systems in which CO₂ is stored for use with the incubator.

WARNING



Warning: Important operating and maintenance instructions. Read the accompanying text carefully.



Caution, Hot surface



Warning: Carefully for the glass.

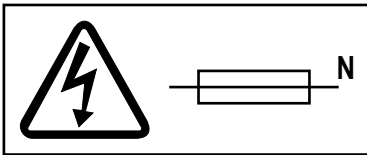

Caution: Double pole/ Neutral fusing.



Warning: Turn off the UV lamp before opening.

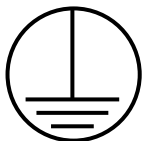

Protective conductor terminal



Caution, Risk of electric shock

Table of Content

S. No.	Contents	Pg. No.
	Glossary	
	Environmental conditions	
	Safety Information	
	WARNING	
	Table of contents	
1	Control panel	1
2	Instruction Manual	2
3	Application	2
4	Abbreviated Operating Instructions	2
5	Description Of The Unit	3
5.1	Structure	3
5.2	Internal System	3
5.3	Heating System	3
5.4	Humidity	3
5.5	Gas Supply	4
5.6	Door Switch	4
5.7	Pressure Compensation	4
6	Microprocessor Controlled System	5
6.1	Physical Parameter Control	5
6.2	Automatic Calibration Of The Measuring System	5
6.3	Monitoring Function	5
6.4	Special Functions	6
7	Over-Temperature Protection	7
7.1	Temperature Limit Controller	7
7.2	Protecting The Unit	7
7.3	Protecting Culture	7
7.4	Operational Test	7
8	Location And Installation	8
8.1	Location	8

S. No.	Contents	Pg. No.
8.2	Space Distance	8
8.3	Stacking	8
8.4	Installation, Connection To Gas Supply	8
8.5	Co2	8
8.6	Reminder	8
8.7	Connection To Main Power Supply	9
9	Start-Up	9
9.1	Operation With Distilled Water	9
9.2	Operation Without Distilled Water	9
9.3	Set Point Adjustment	9
9.4	Factory Settings	9
9.5	Adjustment Of The Temperature Limit Controller	9
9.6	Auto-Start	10
9.7	Special Functions	10
9.8	Notes	11
10	Error Code Table	11
10.1	Error Code Table	11
10.2	Malfunctions Not Displayed	12
10.3	Turn Off The Unit	12
11	Disinfection, Cleaning and Checks	12
11.1	Weekly Checks	12
11.2	Disinfection And Cleaning Of The Interior Chamber	12
11.3	Reminder	12
11.4	Maintenance	13
11.5	UV light	13
12	Technical Data	14
13	Appendix	15
13.1	Stacking Of Incubators	15
13.2	Gas Volume Of Normal Operation And Malfunction	15
13.3	CO2 consumption and pH value	16
14	Service Report	17

CHAPTER 1. CONTROL PANEL:-

1. Displays and Keys: (Figure 1- LCI-100B)

Main Power Switch: Main power switch is to turn the unit on/off, after the power is on, green indicator will light.

2. [°C] Display:

Displays actual temp. value during normal operation. Press [C] key to set temp. and the value can be displayed.

Temp. - Related error codes are displayed by pressing the [i] key. **8** Special functions are available with the  key.

(refer to 9.7 special function).

3. [% CO₂] Display:

- Displays actual CO₂ concentration during normal operation. Press [% CO₂] key to set CO₂ concentration and the value can be displayed. CO₂ - related error codes are displayed by pressing the [i] key.

- Special functions are available with the  key (refer to 9.7 special function).

4. Gas LED Indicator:

The LED is flashing when gases are injected.

5. Heat LED Indicator:

The LED is flashing during heating.

6. [% CO₂]/[°C] Keys:

Set CO₂/Temp. value

7. [▲]/[▼] Keys:

Increase/ Decrease values.

8. [i] Keys:

Error code displays.

9. Keys:

For special function enter a function selection.

10. Control LED Indicator:

The LED is flashing when a special function is selected.

11. "Auto-start" Function Indicator.

12. Over-temp limit: controlling indicator (red lamp) is on when the set temp. is exceeded.

13. Over -temp limit: controlling dial.

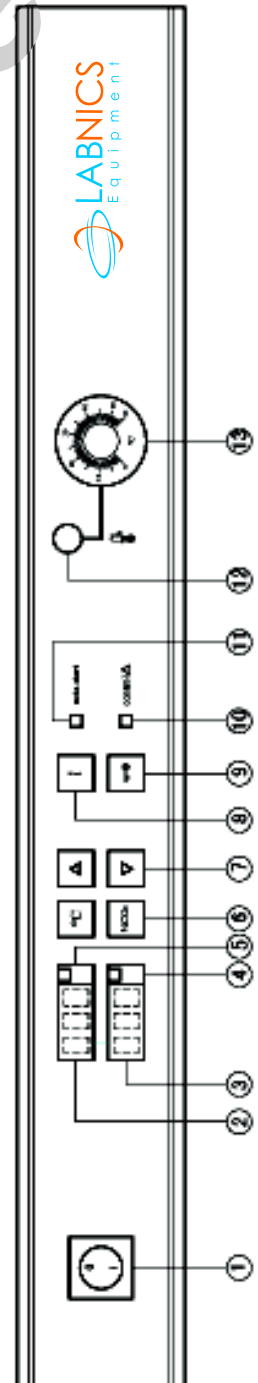

CHAPTER 2. INSTRUCTION MANUAL:-

- Outstanding quality and high economic efficiency features our new Gassed incubator.
- Prior to use, read this manual carefully so that you can operate the instrument properly without causing any damage or bringing any inconvenience.
- Sections regarding safety instructions are printed with **bold** characters.
- Paragraphs dealing with safety precautions are identified by .
- **BOLD LETTERS** highlights sections that are related to proper operation or marked for your special attention.
- Operation of the gassed incubator and its conformity to the relevant safety standards will only be guaranteed if the required tests, maintenance and repairs are carried out by **LABNICS EQUIPMENT** or by technical experts authorized by us.
- When filing complaints or ordering spare parts, please note the data on the nameplate.
- Only trained personnel or expert technicians should operate the unit.
- The unit is in compliance with the following safety standards:
 - DIN 58 945.
 - DIN 12 880 Part 1.
 - DIN VDE 0700 Part 1: IEC 335-1.

CHAPTER 3. APPLICATION:-

- The Gassed Incubator can simulate the natural physiological parameters of cell and tissue cultures.
- The unit must not be used for treatment of flammable materials that may explode.

CHAPTER 4. ABBREVIATED OPERATING INSTRUCTIONS:-

Factory setting: Temperature → 37.0°C, % CO₂ → 0%

Every time startup the unit, the following instructions must be strictly complied:

- Open the glass door, fill in distilled water to the reservoir, close the door.
- Turn the Over-Temperature control knob to 39°C.
- Connect the gas interface of the unit with CO₂ cylinder.
- Adjust the switch on the rear wall of the unit to "**OFF**".
- Connect the unit with power supply and turn the power on.
- The unit will automatically conduct routine self-test, in the meantime, [%CO₂] and [°C] display will show [888].
- After about 40 seconds, self-test is finished, [%CO₂] and [°C] will display the actual value in the chamber.
- Press [▲] and [▼] together for about 10 seconds till [%CO₂] shows [0.0], **AUTO-START** light will illuminate, and then release the two keys.
- The unit will proceed to the **AUTO-START** function.
- Wait for about 16 -24 hours.
- After that, temperature of the unit will show 37.0 ± 0.1°C, CO₂ will show 0 ± 0.1% CO₂, Press [←0] key by one hand, then use [▲] or [▼] key to input temperature set value 3, release the two keys and press [←0] key again, press [i] key to save the setting. In this process, [%CO₂] will show [.0].
- Adjust CO₂ output pressure to 1bar (0.1MPa).
- Press the green [% CO₂] key by one hand, use [▲] or [▼] key to input CO₂ set value(e.g. 7.0% or 5.0%).
- CO₂ gas will be automatically allowed in until CO₂ value set is reached.
- Now the unit is ready for operating.
- After completing the work, carry out the step (Press the green [% Co₂] key by one hand, use [▲] or [▼] key to input CO₂ set value(e.g. 7.0% or 5.0%), to set CO₂ value to [.0]% and then turn off the power. Open the glass door to let the gases come inside the inner chamber and then goes out, wipes off the inner chamber.

CHAPTER 5. DESCRIPTION OF THE UNIT:-

5.1 Structure:-

5.1.1- The outer casing is made of electrolytically galvanized steel sheet and lacquered white (RAL 9002).

5.1.2- The control elements are made of plastic.

5.1.3- The inner casing is made of stainless steel.

5.2 Internal System:-

The pullout shelves are tilt-proof and adjustable over a height of 50mm. Removal of shelves and carrier requires no tools and they can be taken out together at a time.

5.3 Heating System:-

5.3.1- Large-surface heating cables are arranged on the outside of the inner casing, to heat the interior space. The heating cables are placed beneath the water reservoir, on the ceiling, on the upper part of the rear wall and in front of the outer door.

5.3.2- When the outer door is heated, condensation will not happen on the glass door and the interior remains clearly visible in spite of the prevailing high humidity inside. Condensation may occur if the outer door is left open for some time.

5.3.3- The new normal/ slow-heating mode enables the incubator to work properly in different temp. conditions. Normal heating mode is recommended.

The special heating system can efficiently operate on 8°C above ambient temp.. If the unit is to be operated at lower Temp., you can turn off door heating system and the unit can operate on 5°C above ambient Temp. (Refer to section 9.7 Special Function 5: Door heating system). In this instance, you may experience a little condensation on the corner of the glass door. During normal operation, the door heating system is "ON" and the auxiliary heating is going on.

5.4 Humidity:-

5.4.1- The distilled water kept in the reservoir of the unit evaporates and humidifies the working chamber. Under normal operating conditions the relative humidity inside the chamber will be = 95%.

5.4.2- Because of the unique heating system, condensation will not precipitate on the chamber ceiling and the glass door. The sidewalls and the rear wall of the chamber serve as appointed condensation surfaces.

Reservoir Volume: 4L distilled Water

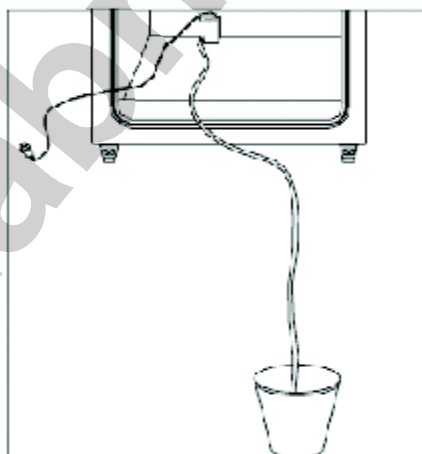

Make Sure that the water used does not contain any chemical agents which may corrode the reservoir.

5.4.3- Water can be removed from the basin using a pump

- Prepare the pipette for removing the water.
- Remove the shelf inside the incubator.
- Connect one side of the pipette with the output of the electric siphon pump.
- Press four suction cups onto the recess on the rear inside the incubator and the bottom of the pump should stick to the power supply of the pump.
- Drain the water until all of them is removed.
- Cut off the power of pump. Then, take it out from the incubator.
- Wipe up the pump and after that remove the pipette.
- Wipe up the reservoir.
- Don't take water to the plug of pump 

5.5. Gas Supply:-

An suited identified connector of CO₂ supply is located on the rear wall of the unit (Fig 3.)



Gas inlet pressure max. 1 bar



Please observe the markings of the CO₂ connector.

Before entering the chamber, the gas passes a sterile filter where particles larger than 0.3 m are retained. Filter efficiency is 99.998%. A small fan ensures that the gas and the incubator atmosphere are thoroughly mixed.

Fig. 3 Connection of CO₂

5.6 Door Switch:-

- There is a door switch located behind the glass door. When the glass door is opened, the gas supply and the heating system gets switched off in order to avoid the uncontrolled admission of gas or heating of the chamber.
- When the glass door is opened all displays flash until the door is shut.
- An alarm will be activated if the door remains open for more than 5 minutes.
- The outer door can only be closed when the glass door is locked and air- proofed.

5.7 Pressure Compensation:-

A pressure compensation vent in the lower section of the chamber rear wall avoids undesirable pressure build-up during admission of gas. This vent is connected with an overflow (unique direction) valve on the rear wall of the unit. The valve impedes unwanted flow of ambient air when the glass door is open. (Fig.4)



The place of installation must be thoroughly ventilated in order to carry off gas escaping around the valve. Don't block this valve.



Fig.4 Overflow Valve

CHAPTER 6. MICROPROCESSOR CONTROLLED SYSTEM:-

6.1 Physical parameter Control:-

6.1.1- Temperature: The temperature of the chamber is precisely regulated by a microprocessor-based control circuit. Platinum Pt 1000 resistance serves as temperature sensor. An Over-Temperature sensor will automatically cut off the heating system and trigger an alarm.

6.1.2 CO₂ control:

- In order to keep the pH value of the culture media constant at a set value, you need to control the CO₂ concentration of the chamber atmosphere. The relevant CO₂ concentration depends on the desired pH value and the content of sodium bicarbonate buffer in the medium.
- CO₂ measurement is based on continuous measurement of the thermal conductivity of the chamber atmosphere. The lower thermal conductivity of the entering CO₂ alters the thermal conductivity level of the chamber atmosphere. This generates an electric signal that is directly proportional to the CO₂ concentration.

6.2 Automatic Calibration of the Measuring System:-

AUTO-START Routine:

6.2.1- Start-up the unit or changing the set temperature requires calibration of the various measuring system. The incubator performs this task automatically during the **AUTO-START** routine.

6.2.2- When both temperature and humidity have reached the steady state, the microprocessor recognizes and performs a fully automatic calibration of the measuring system.

6.2.3- When the temperature equals to the ambient, this process requires approximately 15 hours. Prior to **AUTO-START**; make sure that the chamber is void of all gases, except air.

Advice: Carry out **AUTO-START** program once every 6 weeks.

6.3 Monitoring Functions:-

6.3.1- Door Control:-

All actual value displayed will flash as soon as the outer door is opened and will continue to do so until the door is properly closed again. If the door remains open for more than 5 minutes, the unit would generate an error message and relative error code can be read.

6.3.2 Error Recognition:-

A microprocessor reliably monitors all chamber atmosphere parameters and detects any malfunctions that might occur. All set values have a definite tolerance range. An error message will be displayed if the actual value exceeds the tolerance range.

6.3.3 Tolerance Range:-

- Temperature: $\pm 0.5^{\circ}\text{C}$
- CO₂ content: $\pm 1.0\% \text{CO}_2$

6.3.4 Error Messages:-

- Errors detected by the microprocessor are assigned to special code numbers. These code numbers assists us in identifying the malfunction.
- When control circuit or displays are affected (e.g. door is open), LED will light to remind you of the malfunction in the unit, alarm could be heard if buzzer is connected. Press [i] key to get the error message. The displays will show [---] if there are no errors.

If a malfunction occurs, you should first press the [i] key to get error message.

6.3.5 Alarm:- The error message will be deleted if:

- Set point changes.
- Turn the unit off/ on.

6.3.6 Error Code Table:-

(SP)= Set Points

Error Code	Possible Reason	Recommended Actions
99 Glass door is open	Doors are not closed	Shut doors
100 Temp. is too low (SP)	Temp. limit controller is set too low, observe the indicator	Check temp limit controller adjustment refer to page 12 Turn off the door heating switch (9.7 Function 5)
101 Temp. is too high (SP)	Ambient temp. is too high	
200 CO ₂ too low (SP)	CO ₂ is not connected CO ₂ cylinder is empty CO ₂ inlet pressure is too low	Connect gas supply Refer to installation Replace CO ₂ cylinder Adjust inlet pressure: 1 bar
201 CO ₂ too high (SP)	CO ₂ inlet pressure is too high	Adjust inlet pressure: 1 bar

6.4 Special Functions:-

For adjustment, refer to section 9.7

Use the Function Key, identified by a [i] symbol to select the special functions below.

6.4.1 Buzzer ON/OFF:

Function 1:

- If the buzzer is turned on you will get an acoustic alarm when error occurs.
- Buzzer **OFF**: "Silent" alarm.
- **Factory Setting**: Buzzer ON.

6.4.2 Gas ON/OFF

Function 2:

- With the selection of "**Gas OFF**", the gas supply is cut off permanently; the green LED "**Gas**" is extinguished.
- **Factory Setting**: Gas ON, the green LED "**Gas**" will light.

6.4.3 CO₂ zero-calibration

Function 3:

In case the CO₂ deviation is too large, this function will assist you to calibrate CO₂ zero point.

6.4.4 Set point Lock-in:

Function 4:

- This function permits you to lock the set points you have entered for temperature and CO₂ so that these values cannot be changed inadvertently.
- Factory setting: set point unlocked.

6.4.5 Door heating system on/off:

Function 5:

- Normally, the working temperature is 8°C higher than the ambient temperature. If the unit is to be operated at lower temperature, it can be used at only 5°C above ambient by turning off the "**soft**" switch of function 5. In this instance, you might experience a little condensation on the glass door.
- **Factory setting**: Door heating system "**ON**".

6.4.6 Heating mode normal/ slow:

Function 6:

It provides two heating modes: normal and slow. This ensures the indicator to work well under different temperature conditions. Slow mode is usually used under high ambient temperature. Normal heating mode is recommended.

Factory Setting: Normal mode.

6.4.7 Operation Modes: With / Without water:

Function 7:

If you want to run your unit without water in the reservoir you need to select this mode prior to the start-up.

Factory Setting: To be run with water in the reservoir.

CHAPTER 7. OVER-TEMPERATURE PROTECTION:-

7.1 Temperature Limit Controller- (Responds To temperature):-

7.1.1- The unit features an independent electronic temperature limit controller to protect the incubator, it prevent the working chamber from getting inadmissible excess temperature (refer to figure 1). (it is in compliance with Thermal Safety Class 3.1 and in accordance with DIN 12 880).

7.1.2- In case of a temperature control circuit malfunction and the set temperature is exceeded, the temperature limit controller will take over the control function.

7.1.3- Setting it requires a tool (a coin or screwdriver, for example); refer to Section 9.5.

7.2 Protecting The Unit:-

If you set the control knob to 55 °C (limit stop) the temperature limit controller will protect the incubator.

7.3 Protecting Culture:-

7.3.1- The temperature limit controller will protect the culture if you set it approx. 1-2 °C higher than the temperature selected by the microprocessor.

7.3.2- The red indicator will illuminate as soon as the temperature limit controller responds.

7.3.3- In case the temperature limit controller has taken over the control function, refer to 10.1 Error Code Table to investigate and judge the cause of the malfunction.

7.4 Operational Test:-

At reasonable intervals your temp. limit controller should be tested for proper operation. To run this test, turn the knob to where it shows approx. 2°C less than the temp. indicated on the display. The red indicator must illuminate. We recommend that your authorized operators run this test on routine basis, e.g. prior to a long term working process.



CHAPTER 8. LOCATION AND INSTALLATION:-

8.1 Location:-

- Unpack your unit and take out the accessories from interior. Do not move it by lifting the door.
- It must be located in a dry position and the ambient Temp. should not exceed 30 °C.
- Place the unit on a leveled, non-combustible surface that does not vibrate and make sure that the unit is leveled.
- The gassed incubator will run with CO₂ and CO₂ can do harm to human health. Therefore, you must make sure that the location where the incubator is kept should be properly ventilated. The gasses escape from the back wall must be carried away without any restrictions (evacuated into the air or removed via an exhaust duct).
- The unit should not be placed and operated in places with bad ventilation.
- If several units are placed in the same room or if the unit is installed underneath a laboratory bench, additional ventilation equipment must be provided.
- For information on gasses released during operation or when functioning, consult the Appendix.

8.2 Space Distance:-

Required spacing between the incubator and adjacent walls/objects (Refer to figure 5): All measurements are in mm.

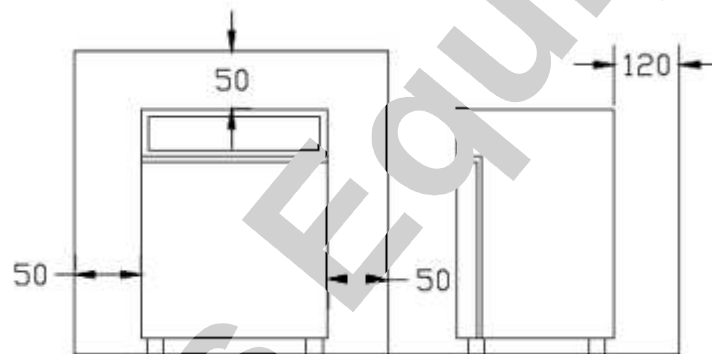

LCI-100B

Fig5. Space distance when placing the incubator.

8.3 Stacking:-

Refer to section 13.1

8.4 Installation, Connection To Gas Supply:-

The appropriate interface is placed on the back of unit. A relative hose is provided with the unit. The gas required for operation of the unit is to be connected via a pressure reduction valve, set at 1 bar. The pressure

- reduction valve will only be supplied on customer's request.

For technical safety reason, the 1 bar setting must not be changed.

8.5 CO₂:-

Connect the gas cylinder with the pressure reduction valve on to the unit.

8.6 Reminder:-

The gases must be at least 99.5% pure.

Do not use a CO₂ cylinder with a cart.

8.7 Connection To Main Power Supply:-

- Prior to connecting the unit to mains, make sure that the power supply ratings matches as those stated on the nameplate.
- Your Gassed incubator is equipped with a properly grounded power supply cable.
- A 6.3 a delay-action type fuse is required for mains fusing.

CHAPTER 9. START-UP:-

The ambient temperature of the location must be at least 8°C lower than the temperature setting.
Keep the outer door and the glass door open.

9.1 Operation With Distilled Water:-

- Fill the reservoir with distilled water at approx. room temperature. Filling level: 4L.
- Make sure not to spill any of the water when filling the reservoir.

9.2 Operation Without Distilled Water:-

1. Consult the special function table (section 9.7) and select Function Code 7, "**Operating mode w/o water**" and enter [U .O].
2. Make sure that the relative humidity inside the chamber does not change. Only use sealed culture dishes.
3. Open the valve on the gas cylinder.
4. Turn on the main power supply.
 - Green indicator illuminates.
 - The display reads [888] for approx. 40 seconds
 - Auto-start routine.
 - After the unit has gone through the auto-start routine, the displays will indicate the actual values.

9.3 Set Point Adjustment:-

1. Use: Set point adjustment [°C], [CO₂], [▲]/[▼] keys.
2. To adjust [°C], press the relative set point key [°C].
3. To adjust [CO₂], press the relative set point key [CO₂].
 - The adjusted set point is displayed.
 - The last digit on the display is flashing.
 - Use the [▲] or [▼] key to adjust the desired set point.
 - If you release the set point key, the new set value will be stored and the actual value is displayed again.

9.4 Factory-Settings:-

- Temperature: 37.0 °C
- Co₂: 0.0%

9.5 Adjustment Of The temperature Limit Controller:-

Set it approx. 1-2 °C higher than the selected temperature. Refer to section 7
"Over temperature protection".

9.6 Auto-Start:-

9.6.1 Attention! The chamber must be void of any gases, except air.

1. Press both the [▲] and [▼] key for approx. 10sec.
2. The **AUTO-START** routine is activated and the CO₂ display will reflect [0.0] after closing the door.
3. Gas LED is off.
4. Shut the doors.

9.6.2 Reminder:-

1. The unit proceeds to heat up to the adjusted temperature set point and builds up the relative humidity.
2. After finishing the Auto-Start routines
 - LED AUTO-START is off.
 - Actual values are displayed.
 - LED Gas is on.

9.6.3 If you enter the CO₂ set value, gas will be injected until the adjusted set point is reached.

9.6.4 The unit is now ready for working.

9.7 Special Functions:-

9.7.1 Keys to be used: [—0] key and [▲]/[▼] keys.

9.7.2 If you keep pressing the [—0] key, you can select and set special functions with the [▲]/[▼] keys.

9.7.3 The [°C] display will reflect the function code, e.g. [.1]. If you release the [—0] key and then press it again, you will get the status report in the CO₂ display:

Function Code	Temp. Display [°C]	Display [CO ₂]	Function	Factory Setting
1. Buzzer	[1]	[A 1] [A 0]	Buzzer ON Buzzer OFF	Buzzer ON
2. Gas	[2]	[G 1] [G 0]	Gas ON Gas OFF	Gas ON
3. CO ₂ Zero- Calibration	[3]	[.0]	CO ₂ calibrate	
4. Set Point Release	[4]	[S 1] [S 0]	Not released Released	Released
5. Door Heater	[5]	[d 1] [d 0]	On Off	On
6. Heating Mode	[6]	[H 1] [H 0]	Normal Slow	Normal
7. Operation Mode	[7]	[U 1] [U 0]	With water Without water	with water

For more information, refer to section 6.4

9.8 Notes:-

9.8.1 Temperature:-

If you change the temperature set point by more than 1°C, you will have to restart the unit as described in the chapter for start-up so that the gas detectors will operate with the utmost precision.

9.8.2 CO₂ Comparison:-

If a precise CO₂ comparison measurement should reveal a concentration that differs a lot from the actual value displayed, you can manually correct the CO₂ measuring system while it is running. In this way you don't need to start the unit all over again.

9.8.3 Reference Example:

Conditions: CO₂ display: 7.0% CO₂

CO₂ measured: 6.2% CO₂

- Use the [←0] and the [] keys to select function code 3.
- Release the [←0] key.
- Keep pressing the [←0] key again.
 1. The temperature display indicates [3].
 2. The [%CO₂] display, [0].
- Use the [←0] + [▲]/[▼] key to set the measured concentration in the temperature display, for examples?[6.2].
- Release the [←0] key.
- Press the [i] key briefly to confirm ?to start computation by the microprocessor?.
- The CO₂ display will indicate the corrected concentration after the computation is completed. If you now find that the actual value displayed exceeds the set point, you will have to open the doors for approx. 15 sec. in order to evacuate the excess gas.

9.8.4 General Remarks:-

- If you do not operate your unit for quite some time, you must drain the water from the reservoir and wipe up the chamber surfaces.
- Do not turn the unit on and off continuously.
- In order to keep recovery times as short as possible and to create optimum chamber conditions, only open the door when needed and keep opening time as less as possible.

9.8.5 [i] Key:-

The relevant displays will illuminate if you are experiencing malfunctions during operation. If the buzzer is connected, you will get an acoustic alarm at the same time. Press [i] key to get information of the malfunction. The affected display [--] will show the error code. (Refer to error code table, section 10)

CHAPTER 10. ERROR CODE TABLE:-

10.1 Error Code Table:-

In order to correct malfunctions as soon as possible in case of an error, refer to the following error code table.

Error Code	Possible Reason	Recommended Action
99 glass door is open	Doors are not closed	Shut doors
100 Temp. is too low (SP)	Temp. limit controller set is too low. Observe the indicator	Check and adjust temp. limit controller
101 Temp. is too high (SP)	Ambient temp. is too high	Turn off the door heating switch (Section 9.7 Function 5)
200 CO ₂ concentration is too low (SP)	CO ₂ is not connected CO ₂ cylinder is empty CO ₂ inlet pressure is too low	Connect gas supply Replace CO ₂ Cylinder Adjust inlet pressure: 1 Bar
201 CO ₂ concentration is too high (SP)	CO ₂ inlet pressure is too high	Adjust inlet pressure: 1 bar

* If this does not work, call a service technician for help.

SP= Set Point

10.2 Malfunctions Which are Not Displayed:-

Malfunction	Recommended Action
*Unit does not heat	Check set points
*Unit does not input gas	Observe LED gas *Check whether gases are released check set points
*Buzzer does not sound if a malfunction occurs	Check to make sure buzzer is turned on, refer to section 9.7 special functions
*Set points cannot be changed	Set points are locked in, refer to section 9.7 special functions
*A lot of condensation on the glass door	Check switch of outdoor heating. Refer to remark on section 9.7 special function 5

10.3 Turn Off The Unit:-

1. Turn off the main power switch.
2. Shut the pressure reduction valve of gas supplier.

CHAPTER 11. DISINFECTION, CLEANING, CHECKS:-

11.1 Weekly Checks:-

1. Check level of distilled water in the reservoir.
2. Check if the gas supply pressure is at 1 bar.

11.2 Disinfection and Cleaning of the Interior Chamber:

1. Turn the unit off before cleaning the incubator.
2. Open the glass door.
3. Drain the water (refer to section 5.4.3).



11.3 Reminder:-

The gas analyzer should only be treated by the recommended disinfectants.

1. Do not use disinfectants containing alcohol.
2. Prior to calling service for maintenance and repair work it might be necessary to clean or disinfect the unit. Alcoholic disinfectants are those that contain more than 10% alcohol when diluted for use.

11.4 Maintenance:-

You'd better run AUTO-START to calibrate the gas analyzer every 2 months.

- We only guarantee safety of the unit when maintenance, repairing or modifications are conducted by personnel authorized from **LABNICS**. Make sure to check your unit at reasonable intervals for proper operation.
- The unit should be checked for safety, leak proof and serviceability at least once a year.



11.5 UV light:-

In operation, fungi may grow up in the incubator, to protect the unit from contamination and keep the cleanness of the sample in the chamber; UV light can be applied to disinfect the inner chamber.

11.5.1 Location of UV light:-

- UV light lamp is located on the upper part of rear wall of the inner case. It is connected to the microprocessor controller through two special airproof and waterproof silastic lamp socket. The protection switch (**UV** light switch) is positioned on the back wall of the incubator and is marked as (**UV**). Please keep the switch off except that you want to use it to prevent any inadvertently triggering.
- After a long-term use, the lamp may damage and two ends of the lamp may turn black and can not be illuminated again. In this case you need to replace the UV light lamp.

Don't Change the UV lamp for yourself, the unit may only be performed by the **LABNICS** or authorized Electronic Engineer.



11.5.2 How To Use the UV Light:-

If you want to turn on the UV light, two switches need to be activated together, one is software switch, Function 222, the other is hardware switch that on the back wall of the incubator.

Steps:

1. Start the incubator and it will experience a routine self-test process that maintains 40 seconds. [888] on the display panel will show the actual value.
2. Before starting UV light disinfecting function, make sure that there is no culture in the incubator.
 - Turn on the UV light protection switch on the back wall of the incubator, set [%CO₂] to [0%].
 - Press and hold [←0] key and press [▲] or [▼] key together, Temp. display shows [222], release [←0] key, then continuously press [←0] key, CO₂ displays [0], thus entering the special Function 222 (UV light switch), press [←0] key and [▲] key, set [%CO₂] to [1], therefore, UV light is on. Press [i] to confirm, UV light will illuminate, display panel shows[---].
 - When the UV light is on, **do not look at the lamp straight!** Turn off the UV lamp before opening the class door!

OFF



UV

ON



3. After 30 minutes or so, disinfection processing ends, UV light in the chamber will extinguish, and display panel will show actual value. Open the outer door and the glass door to let ozone out and then turn off the protection switch on the back wall of the incubator.

CHAPTER 12. TECHNICAL DATA:-

LCI-100B		DATA	UNIT
DIMENSIONS			
Outer Casing	Width	615	mm
	Height	855	mm
	Depth	677	mm
Inner Chamber	Width	470	mm
	Height	607	mm
	Depth	528	mm
VOLUME		151	L
SHELVES			
Full-width shelves		3	
	Max	10	
Dimensions	Width	423	mm
	Depth	445	mm
NET WEIGHT		75	Kg
ELECTRICAL DATA			
	Rated Input Voltage	110	V
	Connected Load/ Rated Power	0.70	kW
	Rated Frequency	60	Hz
	Fuse	AC 130V F6.3A	
TEMP. CONTROL (digital)			
	Temporal Range	R±5..50	°C
	Holding Power at 50°C	0.1	kW
	Spatial Temp. Deviation DIN58 945	± 0.4	°C
	Temporal Temp. Deviation DIN58 945	± 0.1	°C
CO2 CONTROL (digital)			
	Setting Range	0-20	% CO ₂
	Setting Accuracy	0.1	% CO ₂
	Time of Recovery	Ca.1	% CO ₂ / min
	Gas Supply	Ca.3.7	L/min
HUMIDITY			
	Relative Humidity (Constant Humidity)	>95	%
	FINISH Textured lacquer	9002	RAL
GAS SUPPLY DATA			
(Filter in gas pipeline)	Filter Efficiency	99.998	%
	Particle Size	>0.3	µm
	Purity of Gases used min.	99.5	%
	Gas Inlet Pressure	1	Bar
NOISE LEVEL		<60	dB (A)
DISTILLED WATER LEVEL		4	L
CATALOG NO.		03180102	

CHAPTER 13. APPENDIX:-

13.1 Stacking Of Gassed Incubators:-

If several units are placed in the same room or if a unit is installed underneath a laboratory bench, additional ventilation equipment must be provided.

1. One gassed incubators can be placed on top of the other with the provided stacking feet.
2. One set consists of 4 stacking feet to fix the upper unit.
3. The 4 stacking feet shall be screwed with the enclosed self-tapping screws into the holes on the upper part of the unit.

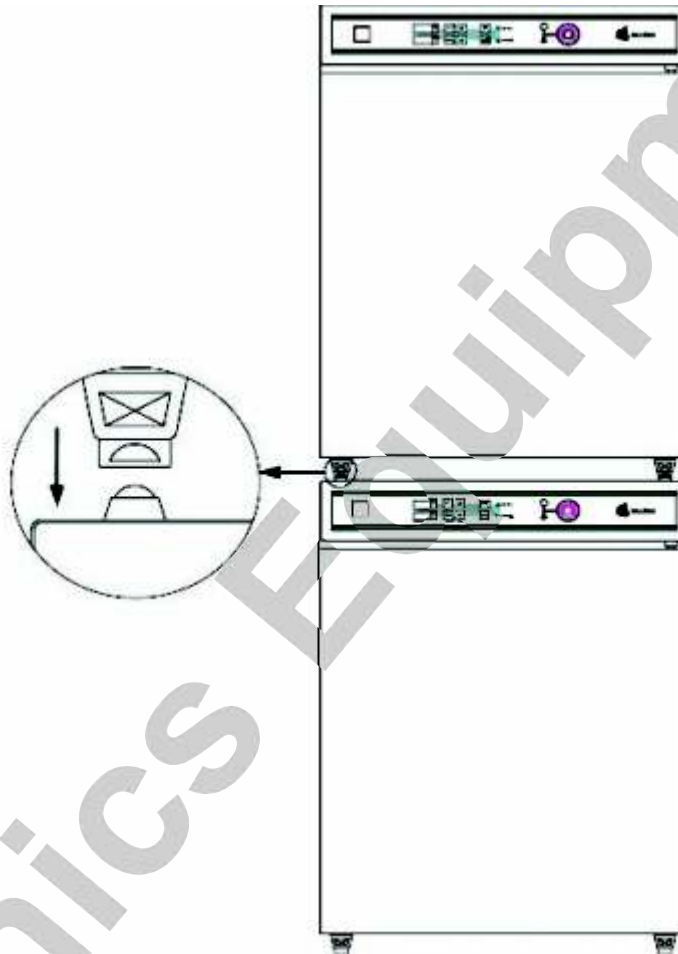

LCI-100B

Figure 6: Stacking the incubators

13.2 Gas Volume for Normal Operation and Malfunction:-

Explanation of Terms Used:

1. **Required Amount of Gas:** the amount of gas needs to be supplied in order to reach the max. Adjustable set point.
2. **Gas Consumption:** The volume of gas injecting to constantly maintain the max. Adjustable set point.
3. **Malfunction:** The gas evacuation volume at the maximum set point that activate visual and acoustic alarm. (duration of malfunction: 2h)
4. **Gas Flow:** With the valve widely open, the max. volume of gas which flowing through the capillaries per hour.

Gas Type	Gas Inlet Pressure	Capillaries	Gas Flow (*4)	Required Amount of Gas (*1)	Gas Consumption	Malfunction: Escaping Amount of Gas (*3)	Limit Value
CO ₂	1 Bar	0.65mm	222L/h	-50L	-0.52L/h	444L	5Vm3

13.3 CO₂ Consumption and pH Value:-

CO₂ Consumption (Working status with closed door), show as figure 7.

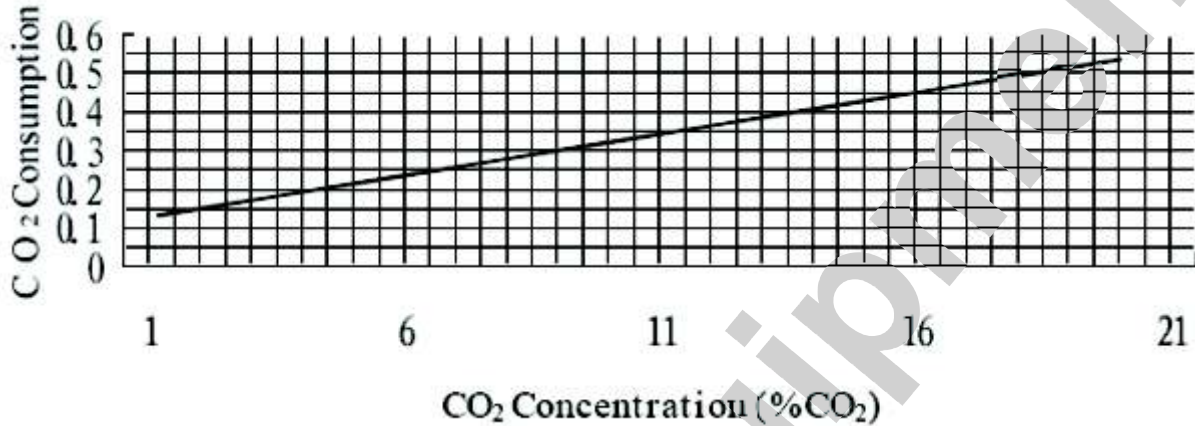

Fig 7: CO₂ Consumption (working status with closed door)

pH value of the culture (necessary for biology cultivating).

pH value of the culture is affected by CO₂ concentration in the chamber; figure 8 show the relationship between pH value and CO₂ concentration.

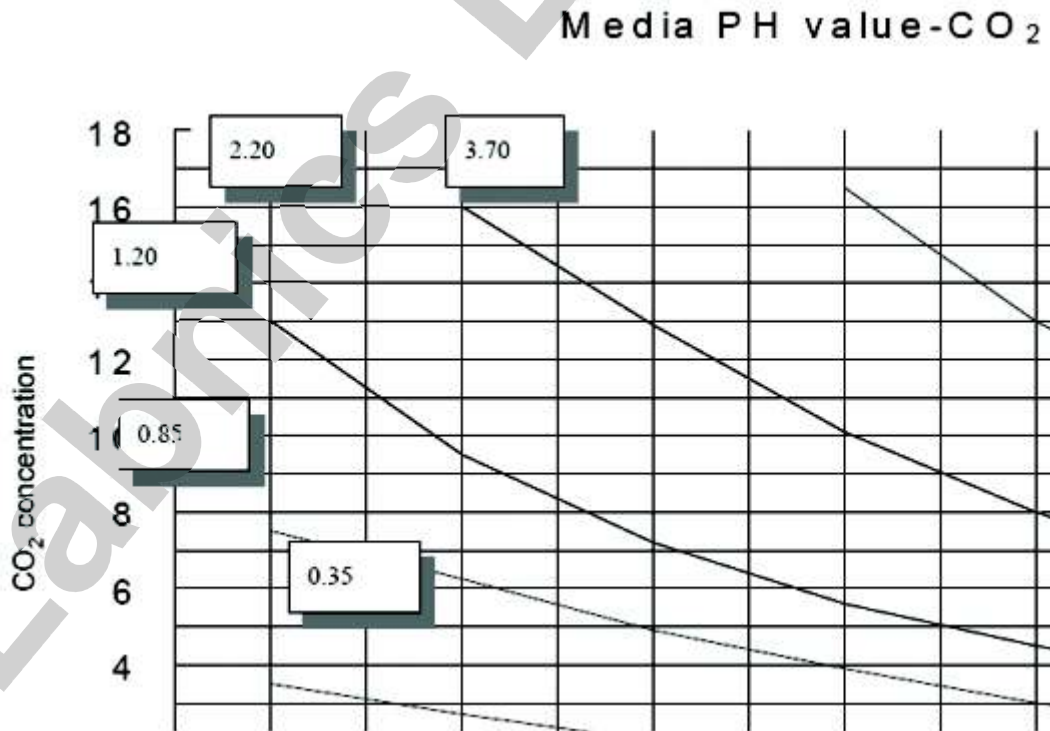

Fig 8. Culture pH Value- CO₂ Concentration

